

Mission and System Design

Alpbach Summer School 2010

Lecture: P. Falkner (ESA)

Contents

- Mission System Design
- Launcher
- Orbits
- Spacecraft Subsystems
- Operations
- Programmatics (Cost, Risk, Schedule)

Mission Design Process

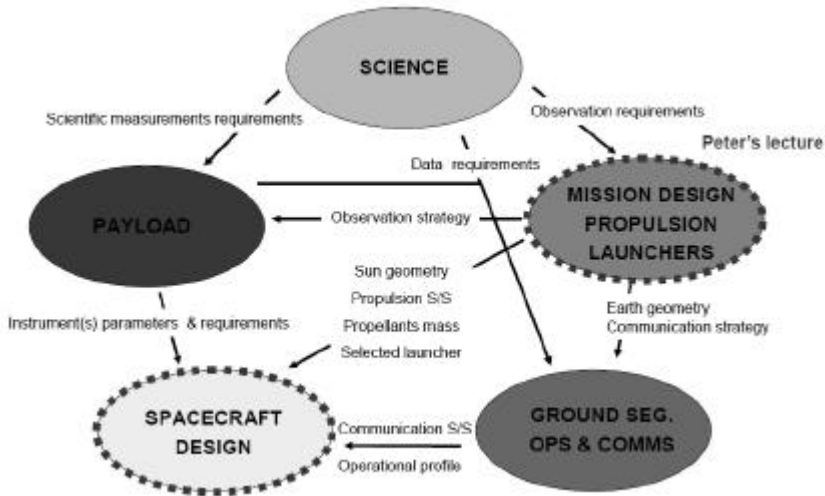

System Design / End-to-End view

Study Phase 0:

- Analysis of Mission Objectives
- Analysis of Mission Constraints
- Definition of Science Requirements
- Definition of Mission Architecture (s)
- Definition of payload / performance
- Analysis of Environment
- Iteration / Trade phase
- Cost, Risk, Schedule, Technology Development

Goal: feasible mission profile satisfying requirements and constraints

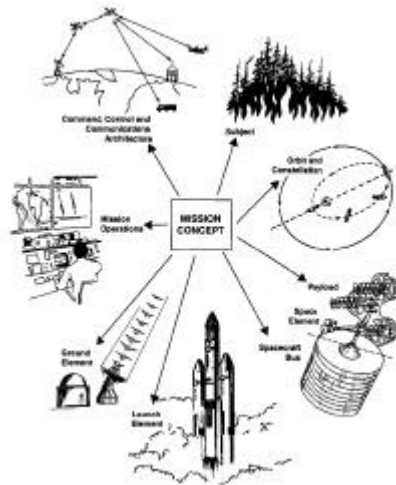

SMAD, p. 13 Space Mission Architecture

Launcher



- Provides access to Space
- **Main trade:** Performance/Cost (end-to-end view)
- Possibility of sharing launch (e.g. Herschel / Planck)
- Trade: direct transfer vs. optimisation of launcher insertion orbit (spacecraft design dependent)
- Attention (!): launch environment/constraints (incl. launch site)
- Soyuz Fregat-2B (70 M€), Ariane 5 ECA (150M€) or ECB (VEGA, 35M€)
- Performance: SF-2B ~ 4900 kg SSO 650km
A5 ~8000 kg SSO 800 km
- For performance => [see launcher user manuals \(web\)](#)

Launcher	Vega	Soyuz	Ariane-5 Generic	Ariane-5 ECA
Orbit	SSO/LEO	GTO	GTO	GTO
Payload mass, kg	1500 (700 km)	3000	6600	10000

SSO/LEO: Sun Synchronous Orbit/Low Earth Orbit, GTO: Geostationary Transfer Orbit

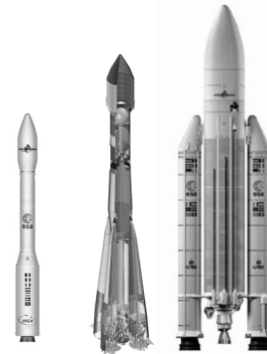

Ariane-5 ECB
GTO
~12000 kg

Orbit Design

Mission Analysis

- Launch and Transfer from Earth
- Insertion into target orbit
- Orbit and Maintenance
- End-of-Life disposal
- Important: Analysis of perturbations e.g. third bodies, solar radiation pressure (translation, rotation), micrometeorites
for LEO: atmospheric drag, J-factors

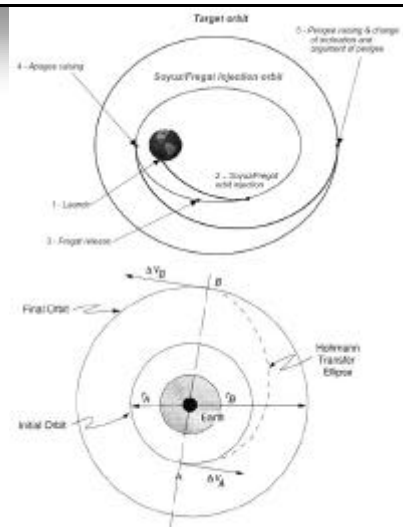

Hohmann Transfer: The Hohmann Transfer ellipse provides orbit transfer between two circular, co-planar orbits.

$$a_D = -(1/2)\rho (C_D A/m)V^2$$

? is atmospheric density, A is the satellite's cross-sectional area, m is the s/c mass, V is the satellite's velocity with respect to the atmosphere, and C_D is the drag coefficient

$$a_R \approx -4.5 \times 10^{-6} (1+r) A/m$$

Solar radiation: A is the satellite cross-sectional area exposed to the Sun in m², m is the satellite mass in kg, and r is a reflection factor.

Target Orbit Selection

Driven by (contradicting) requirements:

- Resolution, revisit time, link budgets, visibility from ground stations, eclipse duration
- Cost of orbit acquisition and maintenance (e.g. drag, J-term perturbations, 3rd body perturbations etc...)
- Illumination conditions

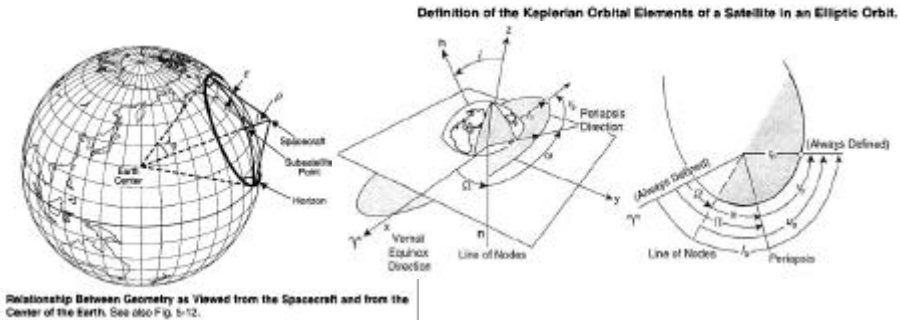

Some Examples

Earth Orbit	Earth Trailing	L2
XMM-Newton 48h, 7000x114000km, 39°, RD[3]	NASA Spitzer Drift-away 0.1AU y ⁻¹	SoHO Only libration mission by ESA, L ₁ , RD[6]
Integral 72 h, 9000x153000 km, 51.6°, RD[4]		Herschel Large-amplitude orbit (quasi-halo), launch 2008, 3-axis platform, RD[7]
Cerret 900 km circular polar LEO		Planck 15° Lissajous orbit, co- launch with Herschel, spinner, RD[7]
ISO 24 h 1090x70500 km, 5.3°, RD[5]		GAIA 15° Lissajous orbit, launch on Soyuz 2-1b from Kourou, spinner, RD[8]
HST 600 km circular 28° LEO		

Many EO missions are either in Sun Synchronous (SSO) or polar circular orbits.

Distinguish: Primary structures (carrying s/c major loads), secondary structures (carrying equipment) & Appendages

- Structure need to provide stiffness in all mission modes (most driving launch, main propulsion manoeuvres, separation of stages, pyros firing etc.) at lowest possible mass
- **Sizing parameters:** acceleration, shock, vibration, acoustic noise (large surfaces!)
- **Critical parameter:** Strength, stiffness, density, thermal characteristics (expansion, conductivity), handling (machining)
- Thermal deformations / co-alignment requirements
- Eigenfrequencies > launcher induced frequencies = driving stiffness

$$\sigma \equiv \frac{\text{Load}}{\text{Area}} \equiv \frac{P}{A} \quad \text{Stress } s \text{ [N/m}^2\text{]}$$

$$\varepsilon \equiv \frac{\Delta L}{L} \quad \text{Strain } e$$

$$\nu = \frac{\varepsilon_{\text{lateral}}}{\varepsilon_{\text{axial}}} \quad \text{Poisson's ratio}$$

$$E \equiv \frac{\sigma}{\varepsilon} \quad \text{Young Modulus } E \text{ [N/m}^2\text{]}$$

Moving parts:

- Reliability is critical (lubrication in space, long storage, thermal range)
- Introduce vibrations

Examples:

- Launch lock mechanism (hold down release mechanism HDRM)
- Deployment of structure, appendages and booms (e.g. solar panel, sun shield, antennae, ...)
- Separation mechanism (separation of stages, multiple s/c,..)
- Pointing mechanism (e.g. payload, HG-antenna, panels)
- Reaction wheels
- Deployable instrument covers



Mechanism are a source of mechanical noise

- Motors and gears: e.g. Maxon
- Frangibolt® Actuator
<http://www.tiniaerospace.com/fbt/fbfc3-20-16sr2.html>

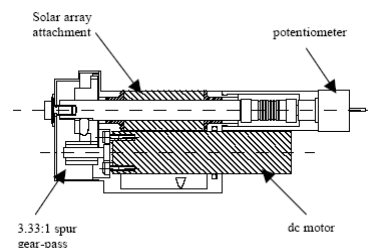

Propulsion

Provides: acceleration and torques
For: transfer, orbit insertion, attitude correction and orbit corrections

- **Main engines** (e.g. 400 N engine, $I_{sp} \sim 320$)
 - large delta-v, large I_{sp} , drive propellant need
 - chemical (solid, liquid mon-, bi-prop),
 - electrical (I_{sp} 3000-4500s)
- **RCS-thruster**
 - Chemical
 - Electrical
 - Cold gas
- Propulsion tanks + pressurant tanks
- Harness, piping

Propulsion Technology	Typical Steady State I_{sp} (s)
Cold Gas	30-70
Solid	280-300
Liquid	
Monopropellant	220-240
Bipropellant	305-310
Dual mode	313-322
Hybrid	250-340
Electric	300-3,000

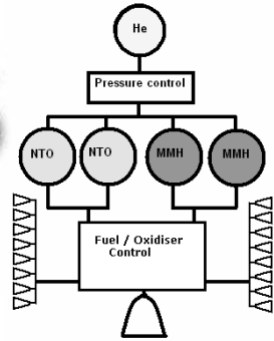

$$m_p = m_f \left[e^{\left(\frac{\Delta V}{I_{sp} g} \right)} - 1 \right]$$

Rocket equation: m_f =dry mass, m_p =propellant \Rightarrow PF excel sheet

Delta-v budget (example)

Manoeuvre	Delta-V	Margin	Total	Source	Notes
Launcher Dispersion	35.0	5%	36.8	Mission	
Orbital Transfer	4.0	5%	4.2	Mission	
Stationkeeping	12.0	5%	12.6	Mission	
Re- or De-Orbiting	0.0		0.0	Mission	
Trajectory Margin	0.0		0.0	Mission	
Cover Ejection Compensation	0.01	100%	0.02	AOCS	Compensate for 45 N force
RW Desaturation	4.9	100%	9.9	Propulsion	Cumulative over 6 years
Field Change Manoeuvre	0.0		0.0	AOCS	Use reaction wheels (no propellant)
Step-and-Stare Manoeuvres	0.0		0.0	AOCS	Use reaction wheels (no propellant)
Safe Mode Reserve	5.0	0%	5.0	Propulsion	
TOTAL			68.45 m/s		

Example of delta-v budget

AOCS (attitude and orbit control system)



Stabilizes the spacecraft against external (and internal) disturbances+ Orbit control and maintenance

- 3-axis or spin stabilized ('gyroscopic stiffness')
- Analysis of pointing requirements (payload, s/c subsystems like antennae, solar panels, etc.)
 - re-pointing (⇒ APE) , duration of starring (⇒ RPE)
 - safe modes, transfer phase, ⇒ all modes need to be analysed
see ESA pointing requirements Handbook
- **Sensors:**
Magnetometer, sun sensor, limb sensor, star tracker, accelerometer, payload, GPS (if available), gyroscopes , IMU
- **Actuators:**
thruster (hot gas, cold gas, electric) ⇒ propulsion system
reaction or momentum wheels, control-moment gyros, magnetic-torquers, 'natural' perturbations, nutation dampers

15

Thermal



Controls spacecraft thermal environment (within operational, non-operational ranges) in various mission modes:

- Launch, transfer, science mode, safe mode, eclipse, etc. ...
- Driven by equipment and payload requirements
- Need careful analysis of all modes (internal dissipation and external input) under various aspect angles.

Sensors: temperature sensors

Control Components:

- Coatings, MLI, paint, radiators, sun shields, foam, heat pipes, optical reflectors, louvers, fillers, thermal insulators, cooler, cold plates, phase change devices, electrical heaters & thermostats, RHU's,....
- Using of emission (e), absorption (a) values
- Requires: Geometrical Mathematical Model (GMM) and Thermal Mathematical Model (TMM) – e.g. ESATAN
- Need to understand the characteristics and dissipation of all s/c equipment

Attention (!) to: thermo-elastics (⇒ co-alignment), outgasing

16

Power

Provides: electrical power to S/C bus and payload

Solar Panel (e.g. triple-Junction cell ~28-32% effic.)

- panels need to point to the sun (dependent on orbit characteristics ⇒ pointing mechanism needed 1-2 DOF?)
- Body mounted (typ. spinner) or panel type (3-axis)
- input at Earth: 1367 W/m² solar flux
- **Batteries**
 - Primary (up to ~350 Whr/kg) and Secondary (re-chargeable, e.g. Li-Ion ~120 Whr/kg)
 - Energy storage
 - needed for emergency (safe mode), eclipses,...
- **Alternative energy sources**
 - Nuclear Power (RTG, RHU's, ASGR's), ...
- **Power Control and Distribution Unit (PCDU)**

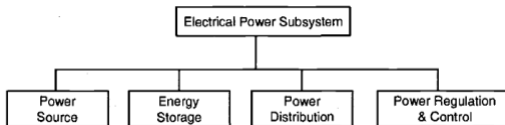

Simplified approach:

- 1) Define driving mode
- 2) Calculate power budget
- 3) Sizing of panels, batteries and PCDU

Data Handling

Onboard Computer System and Memory

- Command Interpretation and execution
- **Data Handling, Processing and Storage**
- Housekeeping handling
- AOCS control algorithm
- Control functions (power, thermal, payload)
- Failure Detection Isolation and recovery (FDIR)

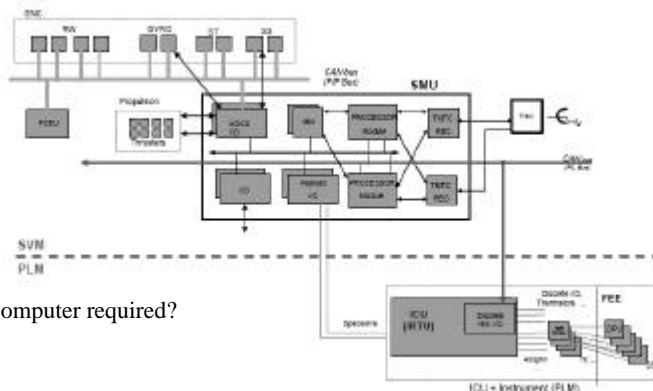

Independent P/L computer required?

Communication and tracking



- Provides communication (RF- or optical link) for:
 - Commanding, housekeeping
 - Data download
 - Radio-Science
 - Tracking (location (range), velocity (doppler))
- Ground station to/from spacecraft
- For longer slant range: X- or Ka-band (others S, UHF)
- Understanding of required data rates ⇒ drives RF system

- VHF:	30 - 225 MHz
- UHF:	225 - 1000 MHz
- L-Band:	1.0 - 2.0 GHz
- S-Band:	2.0 - 4.0 GHz
- C-Band:	4.0 - 8.0 GHz
- X-Band:	8.0 - 12.4 GHz
- Ku-Band:	12.4 - 18.0 GHz
- K-Band:	18.0 - 26.5 GHz
- Ka-Band:	26.5 - 40.0 GHz
- Q-Band:	40.0 - 60.0 GHz
- V-Band:	60.0 - 75.0 GHz
- W-Band:	75.0 - 110 GHz

Link budget:

$$\frac{E_b}{N_o} = \frac{P L_1 G_t L_3 L_4 G_r}{k T_s R} = \frac{[EIRP] L_s L_a \left(\frac{G_r}{T_s} \right)}$$

Energy per bit over noise >3 dB

- P = transmitter power
- L₁ = Line loss
- G_t = Antenna Gain Tx
- L₃ = space loss
- L₄ = transmission path loss
- G_r = Gain receiver antenna
- T_s = Receiver system noise temperature
- k = Boltzmann constant
- R = data Rate
- ? = wave length
- S = path length (distance)

Antenna Gain $G \approx \frac{\pi^2 D^2 \eta}{\lambda^2}$

$$\theta = \frac{21}{f_{GHz} D} \quad \theta \text{ in degrees}$$

3-dB beamwidth

$$L_s = \left(\frac{\lambda}{4\pi S} \right)^2$$

Space loss

See: ESA Ground Station Handbook & Excel sheet & SMAD

Payload & Accommodation



- Science & Measurement requirements drive the Payload Definition
- Specific measurement principles – as discussed in other lectures
 - ⇒ drive the instrument selection and s/c design
- Accommodation (all s/c subsystems might be affected):
 - Mass (Launcher, structure, propulsion system, etc...)
 - Power (power, cleanliness, etc.)
 - Data Rate (DHS, TT&C system, ground station, orbit)
 - Pointing requirements (AOCS and configuration, thermal)
 - Thermal ranges (op/non-op), **cooling required? Active/Passive**
 - Deployment needed (covers, baffles, sun shields...)?
 - Operation / commanding (complexity of modes, calibration)
 - EMC
 - Protection against heat/ radiation / stray light etc.

Operations



- Spacecraft and Instruments need to be controlled from Ground
- Launcher authority takes control until successful launcher insertion orbit and separation from upper/transfer stage

ESA EO missions:

- Mission Operations done by ESOC
 - Navigation and tracking, commissioning, control of s/c, upload of commands, monitoring of health status, planning of manoeuvres etc.
 - Organise download of data for next passes
- Science Operations done by ESRIN
 - Instrument control, definition of instrument commands
- Science data distribution centres
 - Distribution of onboard data together with housekeeping to interested scientists
- Definition of observation cycles/modes

⌚ Do not underestimate cost of mission operation and data management

21

Technology Development



- Technology Readiness is a key system driver
- Assessment of efforts required to reach flight status is difficult
- Assessment done according to the table below

- Non availability of Technology can be detrimental to the schedule and cost

Level	Description
1	Basic principles observed and reported
2	Technology concept and/or application formulated
3	Analytical and experimental critical function and/or characteristic proof-of concept
4	Component and/or breadboard validation in laboratory environment
5	Component and/or breadboard validation in relevant environment
6	System/subsystem model or prototype demonstration in a relevant environment (ground or space)
7	System prototype demonstration in a space environment
8	Actual system completed and "flight qualified" through test and demonstration (ground or space)
9	Actual system "flight proven" through successful mission operations

22

- Cost estimate is very difficult !
 - **3 methods:** Bottom up approach, parametric analysis or by analogy with other missions
 - Need cost model and data base with cost info
 - Most difficult is the estimate on engineering cost, manpower etc.
cost of technology TRL upgrade
 - Cost is driven by complexity of mission

Cost at completion comprises:

- Development cost
- Procurement cost of the space segment (industrial cost)
- Test facilities cost
- Launch cost
- Mission operation cost
- Science operations cost (Data analysis, distribution and archiving)
- Agency cost and margins
- Management costs
- Payload cost

- Space missions are large investments
- Understanding and analysis of risk is important to avoid catastrophic events as much as possible
- Identification of risk followed by risk mitigation is the approach
- Make a risk Register with main risks
- Rated with likelihood (1-5) and severity (A-E)

Score	Likelihood	Definition
E	Maximum	Certain to occur, will occur once or more times per project.
D	High	Will occur frequently , about 1 in 10 projects
C	Medium	Will occur sometimes , about 1 in 100 projects
B	Low	Will occur seldom , about 1 in 1000 projects
A	Minimum	Will almost never occur, 1 in 10000 projects

Risk Severity (1-5)

Severity	Schedule	Science	Technical (ECSS-Q-30 and ECSS-Q-40)	Cost
Catastrophic	Launch opportunity lost	Failure leading to the impossibility of fulfilling the mission's scientific objectives	Safety: Loss of system, launcher or launch facilities. Loss of life, life-threatening or permanently disabling injury or occupational illness; Severe detrimental environmental effects.	Cost increase result in project cancellation
Critical	Launch delayed (TBD) months	Failure results in a major reduction (>90%) of mission's science return	Dependability: Loss of mission. Safety: Major damage to flight systems, major damage to ground facilities; Major damage to public or private property; Temporarily disabling but not life-threatening injury, or temporary occupational illness; Minor detrimental environmental effects.	Critical increase in estimated cost
Major	Launch delayed (TBD) months	Failure results in an important reduction (50-70%) of the mission's science return	Dependability: Major degradation of the system. Safety: Minor injury, minor disability; minor occupational illness; Minor system or environmental damage.	Major increase in estimated cost
Significant	Launch delayed (TBD) months	Failure results in a substantial reduction (>30%) of the mission's science return	Dependability: Minor degradation of system (e.g. system is still able to control the consequences). Safety: Inoper less than minor	Significant increase in estimated cost
Minor	No minimal consequences	No minimal consequences.	No minimal consequences.	No minimal consequences.

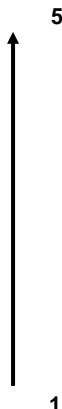

Mission Phases

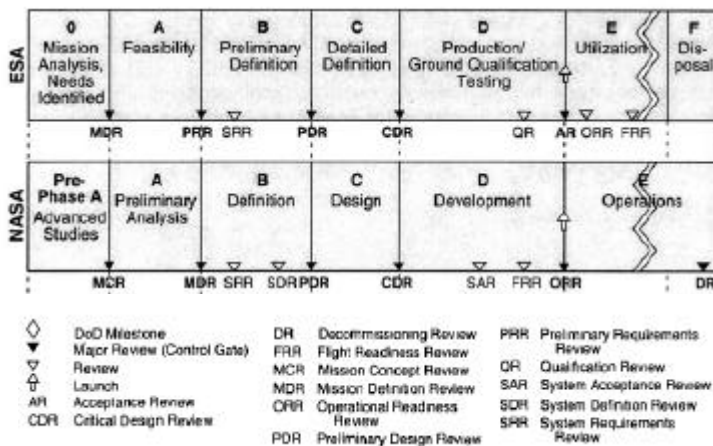

Focus Alpbach:
'Pre-Phase-0'
e.g. proposal preparation

Development Schedule (example)

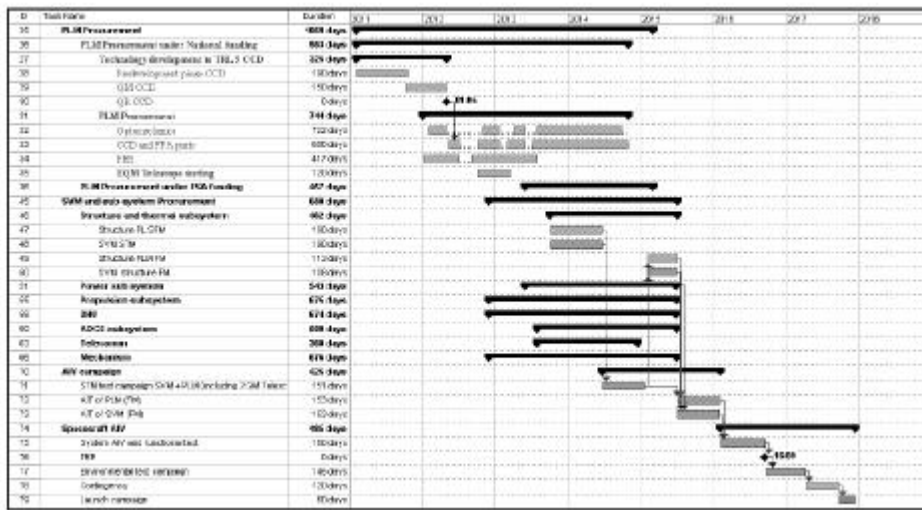

Recommended Literature/References:

1. Space Mission Analysis and Design (SMAD) – microcosm (library)
2. Spacecraft System Engineering P. Fortescue – Wiley (library)
3. ESA track Groundstation handbook (PF)
4. ESA pointing requirements handbook (PF)
5. SF-2B user manual (web)
6. Ariane 5 user manual (web)
7. E.g. Sentinel MRD's (web)

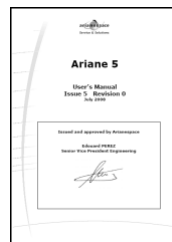

END